

Structure of the Major in Business Technology Management

The major in BTM requires the completion of 24 credits (8 courses). These include six required courses (18 credits) and six additional elective credits offered by the Department.

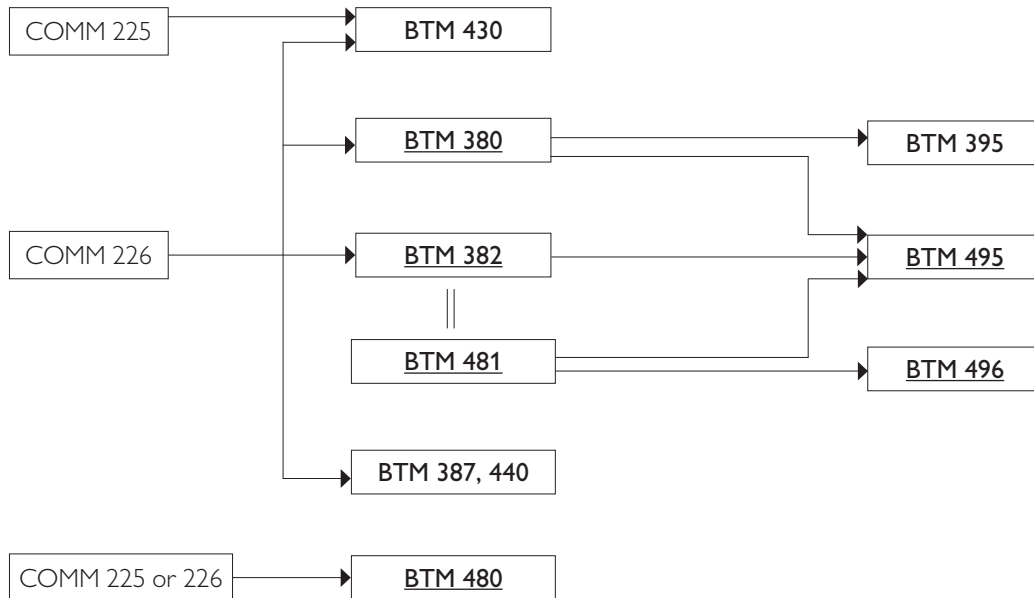

Notes:

1. A *prerequisite* (—>) refers to a course that should be completed before the course that appears at the tip of the arrow. For example, BTM 380 must be completed before BTM 495 .
2. A *prerequisite* or *co-requisite* refers to a course that can be completed in the same term as the course linked by the double line (==). For example, BTM 382 and BTM 481 can be completed in the same term.
3. Business technology management courses are labelled “BTM” and appear **bolded**. The six required courses appear **bolded and underlined**.
4. To review the course requirements for your year of entry in the program please refer to the [undergraduate calendar](#) or [degree worksheet](#) for that year.
5. COMM prerequisites to BTM courses are shown next to the BTM courses.
6. **Students are responsible for following the correct sequence of courses required for the completion of a particular major. Students who fail a course must repeat it before taking the next course.**
7. The Minor in Business Technology Management consists of BTM 382, 387, 481 and 496.
8. The Minor in Data Intelligence consists of BSTA 445, 450, 477 and 478. These courses are not shown in the flowchart.