

Structure of the Major in Accountancy

The major in Accountancy requires 24 credits. They include five required courses (15 credits) and 9 additional credits offered by the Department.

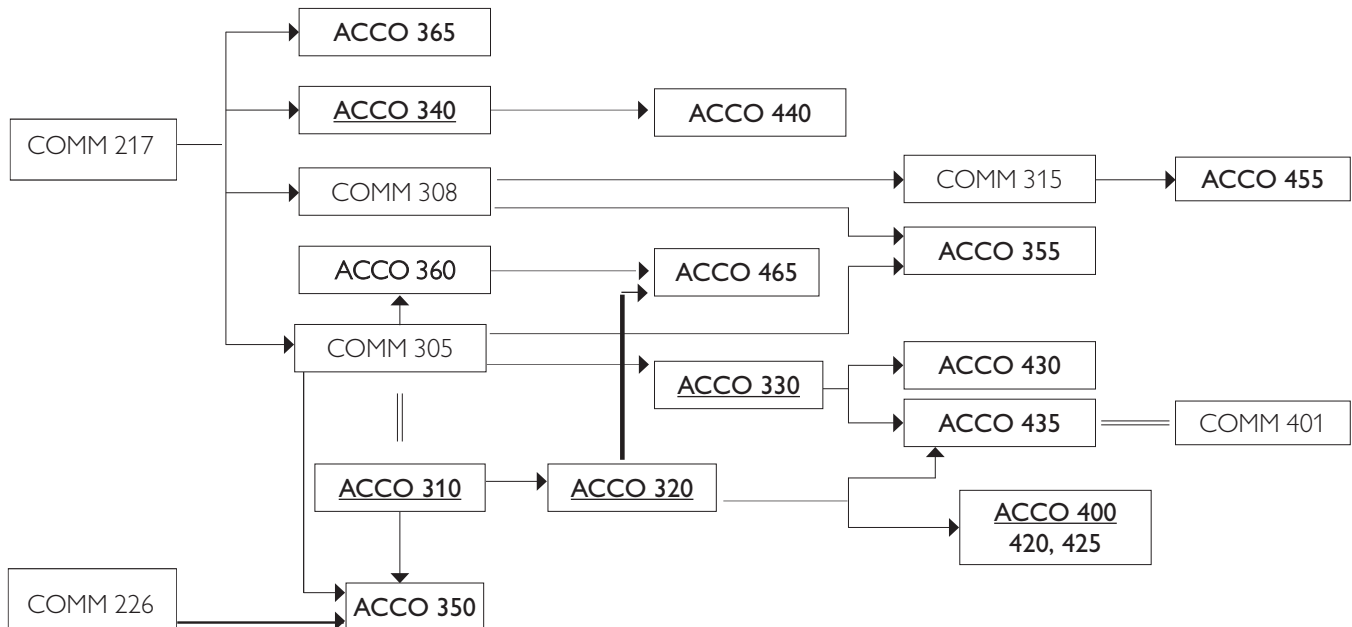

Notes:

1. A *prerequisite* refers to a course that should be completed before the course that appears at the tip of the arrow (→). For example, ACCO 310 must be completed before ACCO 320.
2. A *prerequisite* or *co-requisite* refers to a course that can be completed in the same term as the course linked by the double line (==). For example, COMM 305 and ACCO 310 can be completed in the same term.
3. The accounting courses are labelled "ACCO" and appear **bolded**. The five required courses appear **bolded and underlined**.
4. To review the course requirements for your year of entry in the program please refer to the [undergraduate calendar](#) or [degree worksheet](#) for that year.
5. COMM courses that are prerequisites for ACCO courses are shown before the arrow (→), which points to the ACCO course.
6. Students are responsible for following the correct sequence of courses required for the completion of a particular major. Students who fail a course must repeat it before taking the next course.
7. ACCO 495 is not shown in the flowchart above; it is only available to students in the Honours in Accountancy program.
8. The list of courses required for admission to the Graduate Diploma in Chartered Professional Accountancy (CPA) program is available at: concordia.ca/jmsb/programs/graduate/cpa/admissions
9. The Minor in Financial Reporting consists of ACCO 310, 320 and six additional ACCO credits.
10. The Minor in Managerial Accounting consists of ACCO 330, 430 and six additional ACCO credits.
11. The Minor in Assurance, Fraud Prevention and Investigative Services consists of ACCO 350, 360, 455 and 465.