

DJI Ronin RS2

CDA Quick Start Guide
Setup and Basic Operation

Centre for Digital Arts
Concordia University 2026



Contents

P. 3 What is a camera gimbal?

P. 4 About this CDA Quick Start Guide

P. 5 Setting up the Gimbal

P. 6 Warning about the gimbal motors

P. 7 Steps for setting up the gimbal

- 1. Charge the battery -P. 8*
- 2. Prepare the Camera-P. 9*
- 3. Assemble and Balance the Gimbal- P. 15*
- 4. Test the balance with Auto Tune- P. 23*
- 5. Connect the Camera- P. 25*

P. 28 Basic Operation

P. 29 Winter Warning

P. 30 Operation Modes

P. 32 Follow Modes

P. 35 Manual Control of Axes

P. 36 Other Basic Gimbal Controls

P. 37 Controlling Exposure Remotely

P. 39 Controlling Focus Remotely

P. 40 Important System Settings

P. 41 Create Settings

P. 42 Practical Advice

P. 43 The DJI Ronin App

P. 44 Downloading the App

P. 45 Create Menu Options

P. 48 Accessories

P. 49 Twist Grip Dual Handles

What is a camera gimbal?

A gimbal is a device that allows smooth camera motion when handholding a camera.

The DJI Ronin RS 2 is for small still cameras. It has three motors that balance the movement of the camera. In ordinary use, the motors adjust to the movement of the hand grip. Use the gimbal for travelling shots that follow a subject or move around a subject.

You can also do special effects, like getting the gimbal to execute a series of preprogrammed movements, follow the movement of a phone, or move during timelapse photography.

The drawback, when using the gimbal, is the difficulty in operating exposure and focus settings while shooting. You will want set up exposure before recording and use autofocus.

About this CDA Quick Start Guide

This guide groups essential resources in one place, so you can quickly start using the gimbal. It collects sources of information from the web. Some of the procedures can be followed much easier in videos.

I make specific observations on using the gimbal with the Sony mirrorless cameras and lenses in the CDA EV Depot and refer to specific menu settings in the Sony a7r III camera. But you can use other cameras with similar settings.

Not all the features of the gimbal are covered in this guide.

I recommend the complete DJI user guide that can be found here:

<https://www.dji.com/ca/downloads/products/rs-2>

There a more concise paper DJI quick start guide in the bag, that is much less useful than the complete user guide.

Setting up the Gimbal

DJI Ronin RS2

Centre for Digital Arts

Warning about the gimbal motors

Don't power on the gimbal until the gimbal is balanced and the motors are unlocked.

Turning on the power when any of the gimbals' motors are locked can damage the device.

Steps for Setting up the Gimbal

Follow these steps for setting up the gimbal. They should be followed in this order:

1. Charge the gimbal battery
2. Prepare the camera
3. Assemble and Balance the gimbal (with the camera on it)
4. Test the balance with Auto Tune
5. Connect the camera

1. Charge the battery

The battery is in the grip, and will last for about 12 hours in normal mode but less in super smooth mode.

The gimbal uses less power when it is properly balanced.

There is a USB charging port at the bottom of the grip.

There is only one grip/battery.

Charge the battery in a place above 5° C but preferably at room temperature.



2. Prepare the camera

Which camera to use?

The DJI Ronin RS 2 can work with many still cameras. The complete list can be found on this page:

<https://www.dji.com/ca/support/compatibility>

In this guide, I refer to the **Sony mirrorless cameras** as these are the still cameras in the EV depot with the best video recording quality. However, you can use other still cameras if you wish. Refer to the specific menu settings required for remote control on the DJI compatibility pages.

Do not use the RS 2 gimbal with any video cameras. It is **not** for use with the Sony FX6, FS5 or Z90 video cameras in the EV depot or any other video camera with the exception of Blackmagic “pocket” video cameras.

Although DJI claim that this gimbal can support a 10 Lbs camera (4.5 kg), I remain skeptical. It is difficult to balance the gimbal with a load of half that weight. The smaller and lighter the load, the better the gimbal works.

2. Prepare the Camera

Attachments, batteries and media

Before using the gimbal it has to be balanced with the camera. Prepare the camera so that everything that is needed in and on the camera is attached or inserted.

The neck strap should be removed. Place the battery and SD card inside. Put the desired lens on the camera, the lens hood if required and take off the lens cap.

This advice seems pedantic but if there are any changes to the camera (for example: removing a lens cap or attaching a lens hood), the gimbal will have to be rebalanced.



Sony A7R III with the Sony FE 24mm F1.4 GM prime lens. This is a good lens to use.

2. Prepare the Camera

Avoid heavy zoom lenses.

The Sony mirrorless cameras come with zoom lenses like the Sony FE 24-70 GM mm. There is no benefit to using a zoom lens on the gimbal since you cannot zoom while shooting!

Zooming alters the length of lens that upsets the forward weight of the camera that upsets the gimbal balance. If you use a zoom lens, balance the gimbal with the desired focal length. Changing focal lengths means rebalancing.

Length and weight is an issue. With the Sony FE 24-70 GM mm zoom lens, for example, the gimbal can only be balanced at the shortest focal lengths. So, nothing is gained by using the zoom instead of a shorter, lighter and faster prime lens.

Use small prime lenses on the camera. This will make the camera light and easy to control.



Sony A7R III with the FE 24-70 mm balanced at the 24 mm focal length.

2. Prepare the Camera

Which lens to use?

Any of the Sony prime lenses in the depot are good to use with the Sony mirrorless cameras. The shorter focal lengths are ideal. The larger and heavier the lens, the more work it is to balance the gimbal.

I tested the gimbal with the Sony FE 24mm F1.4 GM and Sony FE 50mm f1.4 ZA lens lenses. Both worked in a similar fashion. With these lenses, aperture and focus can be controlled remotely. Camera and lens control requires a USB C connection from the gimbal to the camera (more on this later).

The DJI compatibility pages do not list all the supported lenses.

<https://www.dji.com/ca/support/compatibility>



Sony a7r III with the Sony FE 50mm f.1.4 lens

2. Prepare the camera

Quick release plate: Put the quick release plate on the camera. There is a higher and shorter quick release plate. The higher one does not lock properly, so use the shorter one only. Mount it on the camera with the arrows pointing forward and backward.



Use the shorter one!



2. Prepare the camera

Which frame rate to choose?

In general, when shooting video with the Sony mirrorless cameras (or other still cameras) use the 30p frame rate rather than 24p when possible. Motion looks smoother at 30p on cameras these cameras.

Shooting at high frame rates for a slow-motion effect (S & Q Mode in the Sony cameras) in conjunction with the gimbal will result in the smoothest possible motion.

Specific menu and camera settings to allow remote control are detailed in the Basic Operation section of this guide.

3. Assemble and Balance the Gimbal

Once you have prepared the camera, you can assemble and then balance the gimbal. This is easier shown on video, rather than described in a pdf. Here are two great video references.

Watch this video by Jason Roberts for a detailed explanation of setting-up the gimbal, balancing and auto tuning the gimbal:

<https://www.youtube.com/watch?v=v0iq89cTDkQ>

Once you are more familiar with the setup, DJI have a shorter, more precise video on balancing. This is good to refresh your memory the next time you balance:

<https://www.youtube.com/watch?v=ObjjN5JxY2k>

On the following pages, I will underline **some important details** about assembling and balancing the gimbal. These comments are to be used in conjunction with the above videos.

3. Assemble the Gimbal

The battery grip:

The battery grip lock is a bit deceptive and not very confidence building.

Press the button inside the lock lever and move the lever to the unlock position to insert the grip, then move the lever to the locked position to tighten. Move the lever as far to the locked position as possible.

There is no click when it locks. It is simply a pressure lock. The grip cannot come loose without the button inside the lock being pressed.

Screw the mini-tripod legs on to the gimbal handle. Set up the gimbal on a hard level surface like a table to do the balancing.



3. Assemble the Gimbal

Expanding the gimbal:

The gimbal is expanded by unlocking the roll axis motor.

The gimbal has three motors for the three axes: tilt, roll and pan.

Lock the motors when mounting the camera to the gimbal.

Always unlock the motors before turning the gimbal on.

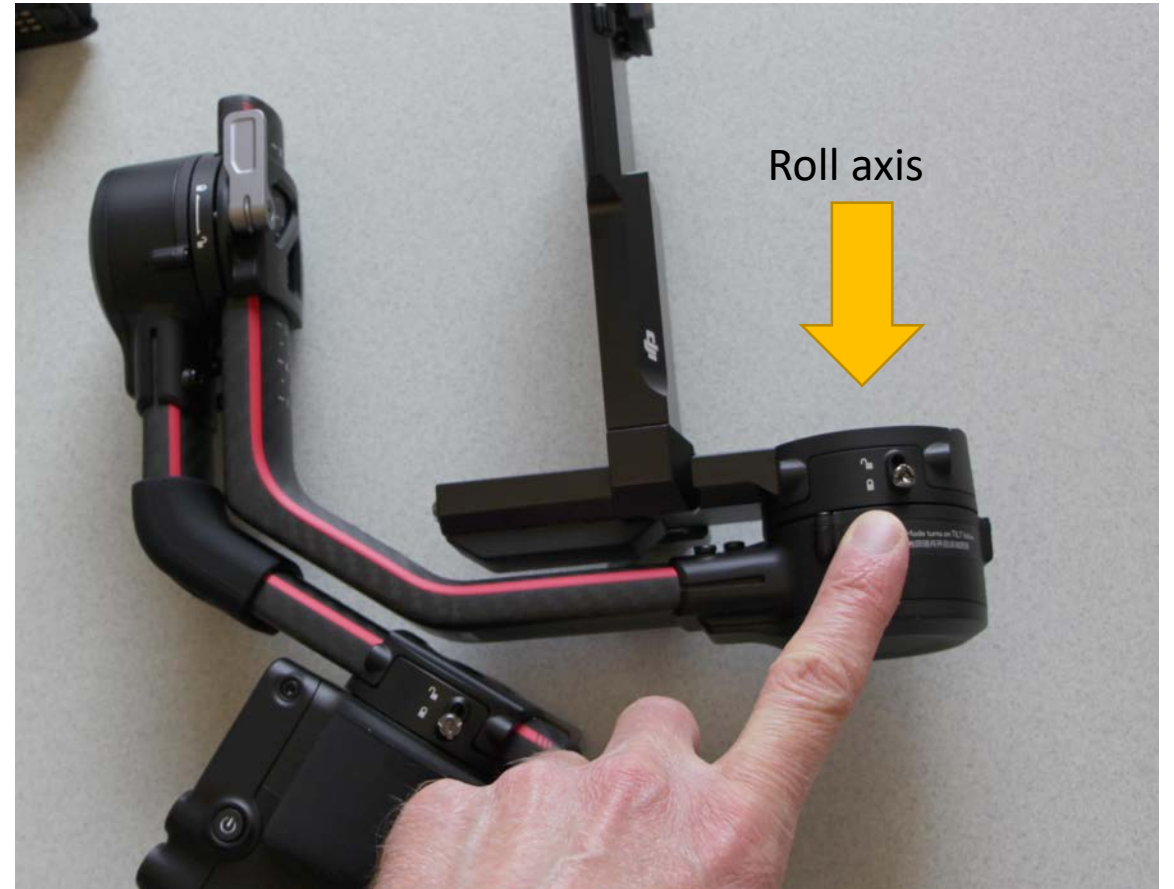

3. Assemble the Gimbal

Gimbal orientation:

This is how the gimbal should be built and orientated. The front of the gimbal has the trigger and dial. The rear has the touch screen. The roll motor is on the back of the gimbal.

The arm with the words “Ronin” is on the right hand side if you are aiming the gimbal forward and are behind the gimbal.



front



left side

3. Assemble the Gimbal

Mounting the camera:

Mount the camera on the gimbal before performing the balancing.

When mounting, do not position the camera too much forward or backwards on the sliding lower quick release plate. Put it in the middle.

Do not tether the camera to the gimbal with the USB cable at this point. Tether the camera after the balancing.

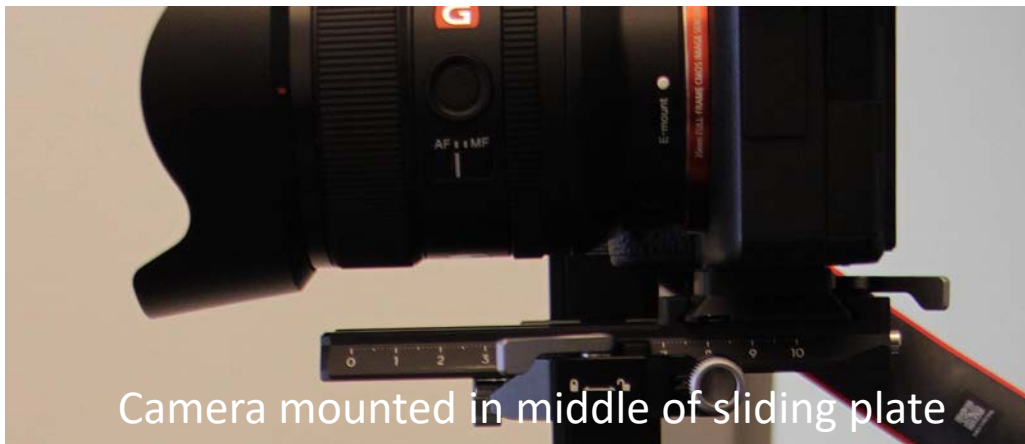

3. Assemble the Gimbal

The lens strap:

There is a lens strap for supporting larger lenses that must be placed on the camera before the gimbal is balanced.

Lenses larger than the 24 mm Sony prime will need the lens strap to help reduce stress on the lens mount. You must also use the lens strap for Supersmooth mode.

The lens strap has two parts: a knob that screws the strap handle into the camera slide plate, and the strap handle with the strap.

See the next slide for two variations on how to mount the lens strap.



3. Assemble the Gimbal

The lens strap:

In the top image, the strap handle is mounted forwards, as suggested by DJI.

In the bottom image, the strap handle is mounted backwards, because that's the only way to make it work!

Do not tie the lens strap on the lens so tightly that it is forcing the lens down. It should be lightly snug around the lens.

Remember to take off the lens strap **before** you unlock the camera from the lower sliding plate.



3. Assemble and Balance the Gimbal

Follow the balancing procedure in the right order:

Follow the balancing process in the instructional videos.

In each of the videos, you will notice that there is a specific order to the balancing process. Make sure to follow the procedures in the right order.

First balance the vertical tilt axis and then the forward tilt axis. Then balance the roll axis and finally the pan axis.

The most difficult part is the first part, the tilt axis.

If you notice that the camera is sometimes tipping forward as well as backwards when you are trying to adjust the forward tilt axis, then the vertical tilt axis has not been balanced correctly. Go back and make small adjustments to the first step, the vertical tilt axis, and then continue with the forward tilt axis. This is especially the case with heavier cameras and lenses.

If you cannot get to the point where the tilt axis is stable, the camera may be too big or heavy. This is not possible if you have used the Sony a7r III with the 24 or 50 mm prime lens.

4. Test the balance with Auto Tune

About the touch screen:

You do not need the Ronin app to operate the gimbal or control the camera. All the basic functions are in the touch screen.

The touch screen has four menus that can be found by swiping in one direction or another.

Swipe up to see the joystick and dial settings. **Swipe left** for system settings. **Swipe right** for shooting modes.

The **main page** has the Auto Tune and follow modes.

Auto Tune

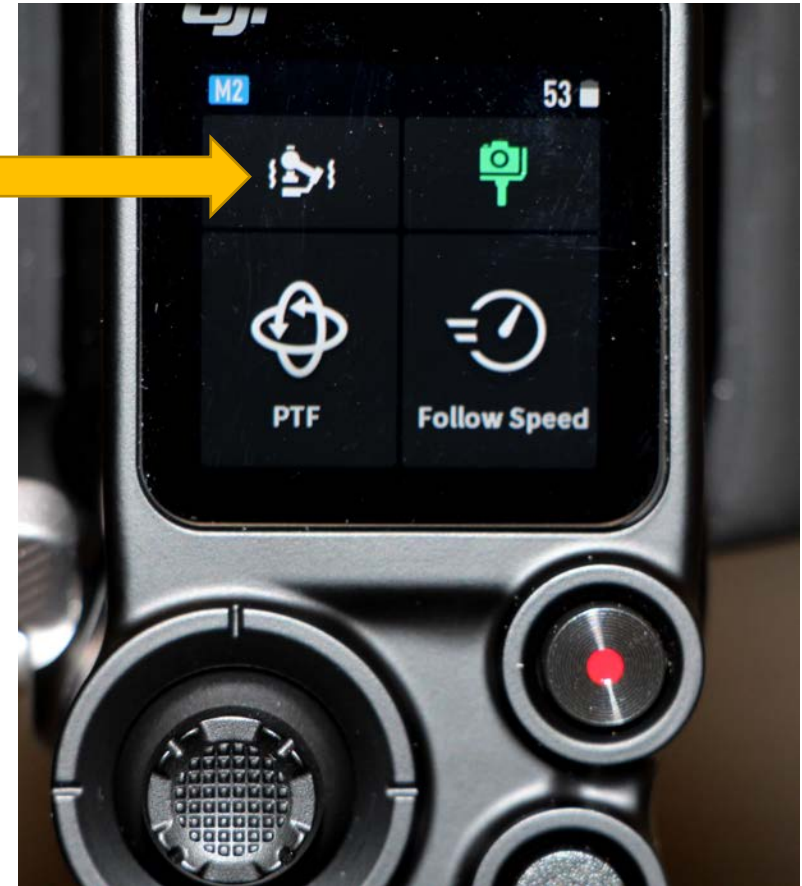

4. Test the balance with Auto Tune

Start Auto Tune:

After you balance the gimbal, unlock the motors of the three axes (tilt, roll and pan) and turn it on.

Use Auto Tune on the gimbal touch screen to test your balancing. The gimbal will shake slightly and make motor noises when this is happening.

If you are using Supersmooth mode, make sure to turn that on and make sure the gimbal has been balanced with the lens support attached.

Rebalance if the icon is red, and consider rebalancing if it is orange.

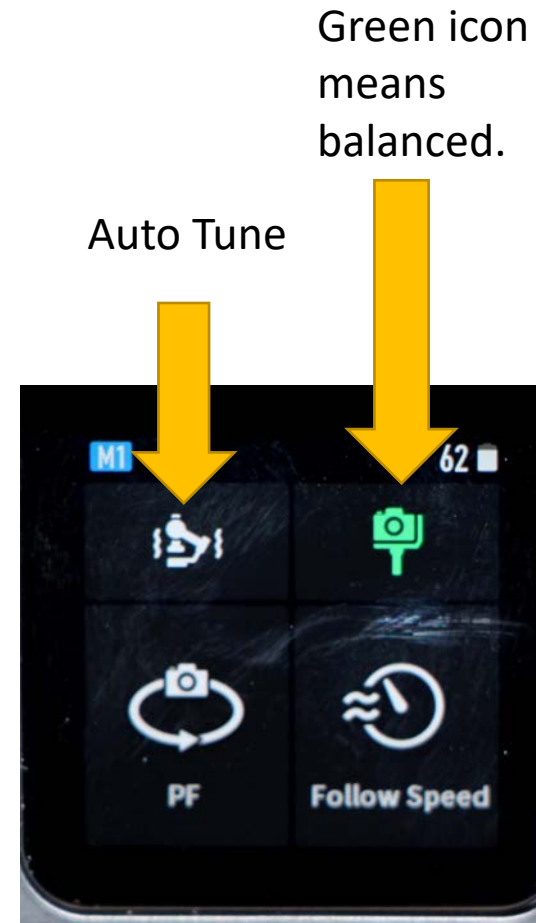

Turn on Super Smooth

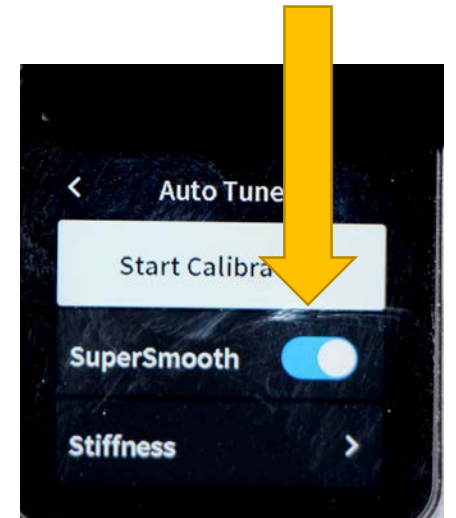

5. Connect the camera

Physical connection:

Once the camera is balanced, connect the camera to the gimbal with a USB C or other cable to control the settings on the camera with the touch screen and dials.

Which cable you use, depends on the model of the camera and what functions you need (see next slide).

The cable goes into the top USB C RSS port next to the tilt axis motor and then to the left-hand side of the camera.



Top USB C port on the gimbal



5. Connect the camera

This page on the DJI Ronin site shows compatibility for different models of cameras and which menu settings to change:

<https://www.dji.com/ca/support/compatibility?product=rsc-2>

What cable you choose can change what features can be controlled remotely.

For the a7r III, the USB C cable is best for video shooting. The Sony Multi cable is necessary for capturing still images in the Timelapse or Panorama functions on the gimbal.

A7R3 + DJI RS 2 Compatibility result

Control Features/Cable	Control Cable (Sony Multi) (in the box)	Control Cable (USB-C) (in the box)
Capture photo	✓	✗
Start/stop recording video	✓	✓
Pull focus electronically	✗	✓
Trigger auto focus	✓	✓
Zoom control(digital or optical)	✓	✗
ISO	✗	✓
Shutter	✗	✓
Aperture	✗	✓
RavenEye	✓	✗

5. Connect the Camera

Menu settings on the Sony a7r III to initiate remote camera control:

1. Go to the Network menu page and turn off “Ctrl w/Smartphone”.
2. Then go to Setup Menu page four and for USB Connection choose “PC Remote”.

Turn OFF the Steady Shot function (Camera menu 2, page 4).

Physical settings on the lens:

For remote focus control, the switch on the lens must be on AF, and for remote aperture control, the f stop dial on the prime lenses should be turned to “A” (auto). See the section on Basic Operation.



Basic Operation

DJI Ronin RS 2

Centre for Digital Arts

Winter Warning

The DJI Ronin cannot be used outdoors in winter conditions below -10°C .

Page 13 of the DJI Ronin RS 2 User manual states that using the grip (therefore the gimbal) below -10°C may cause permanent damage!

Also on that page, it encourages charging the grip in a place that is above 5°C , but ideally at room temperature 22 to 28°C .

Operation Modes: Upright

If you have followed the procedure for setting up the gimbal then it should be in the mode common “upright” operation mode.

This is the most common way to use this gimbal.

The tripod can be folded to increase the length of the grip, it can be expanded against your torso or you can just use the grip.

See the Accessories section of this guide for how to attach the handles.

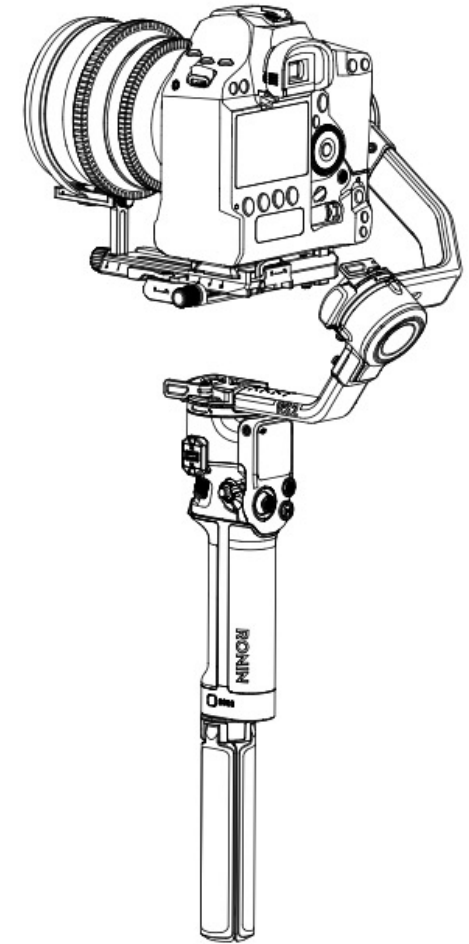

Upright Mode (from the DJI User guide)

Operation Modes: Underslung

Underslung operation is not recommended.

This is when the camera is hanging from the grip.

Depending on the weight of the camera, the handle lock may not be sufficiently strong enough for this operation, despite the claims of DJI. Use at your own risk. Remember that you are responsible for any damages to the equipment.

If you require a low angle shot, attach the twist grip handle in position “2”: page 50 of this guide.

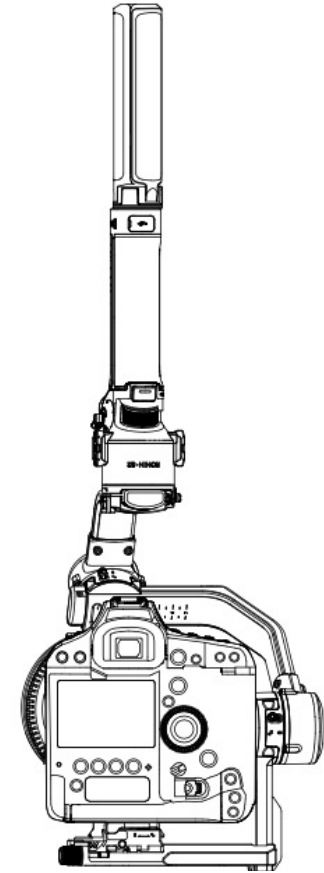

Underslung Mode (from the DJI User guide)

Choose a Follow Mode: Most Common Modes

Which follow mode you choose determines which axes react to the grip's movement.

The follow mode can be chosen on main touch screen page, right below Auto Tune.

The three most useful follow modes:

PF: pan follow- only the pan axis follows the grip's movement

PTF: the pan and tilt axes follow the grip's movement

FPV: the pan, tilt and roll axes will follow the grip's movement (all three axes)

Choose a **follow speed** depending on how quickly you want the gimbal to react.

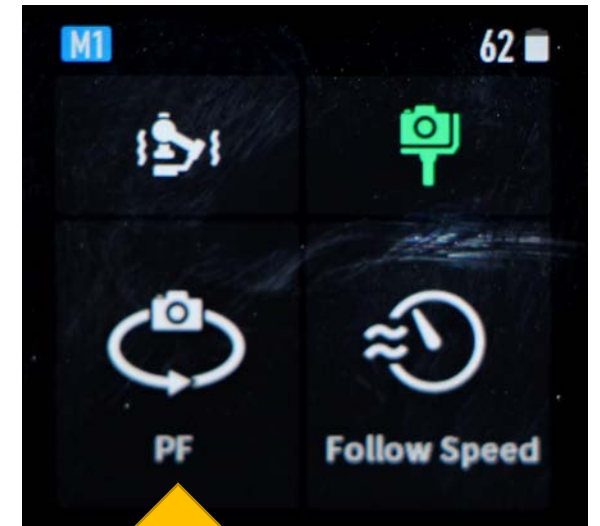

Follow mode

Choose a Follow Mode: Less Common Modes

There are two less common modes:

3D Roll 360: the camera moves into the **flashlight position** (pointing forward) where you can spin it around in a circle with the gimbal's joystick, moving the pan axis left or right.

Portrait mode: this turns the camera 180 degrees so you are shooting vertically instead of horizontally. Keep in mind that vertically shot video will be pillar-boxed on any standard video display.

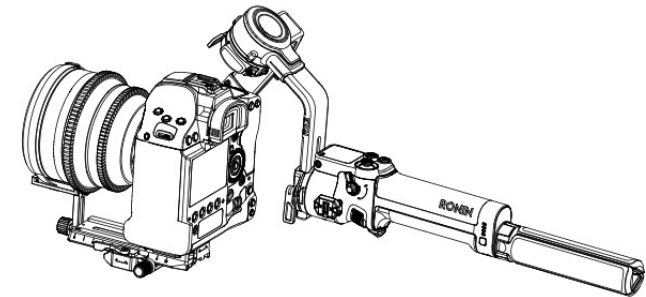

Flashlight position
(from the DJI user guide)

Choose a Follow Mode: Sport Mode

Sport Mode

In addition to changing the follow speed, you can enter "sport mode" for a very quick reaction time. This is for shooting fast moving action.

Press and hold the **M** button on the back of the gimbal. It must be continually held down. You will see a small running person icon in the top of the touch screen. The camera can still be manually controlled in this mode.

Locking in sport mode: While holding down the M button, press the trigger twice to remain in sport mode. While holding down the the M button, press the trigger twice again to exit sport mode.

Manual Control of Axes

Manual control of the axes:

Swipe left on the touch screen to access the system settings and enable **Push Mode**. This allows manual control of the axes.

You can manually control the axes even while the gimbal is automatically adjusting them with the follow mode.

On the back of the gimbal, there is a **joystick** for moving the tilt and pan axis. You can adjust the smoothness and speed of the joystick.

The roll axis is best controlled by the **dial** on the front of the gimbal. This must be set in the dial function menu. **Swipe up** on the touch screen to reach the Dial function menu. Select **Roll**.

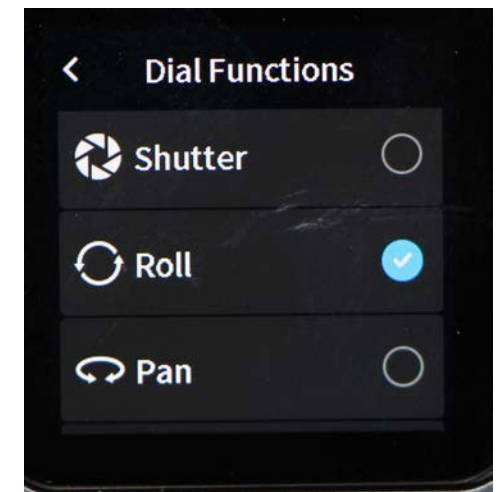
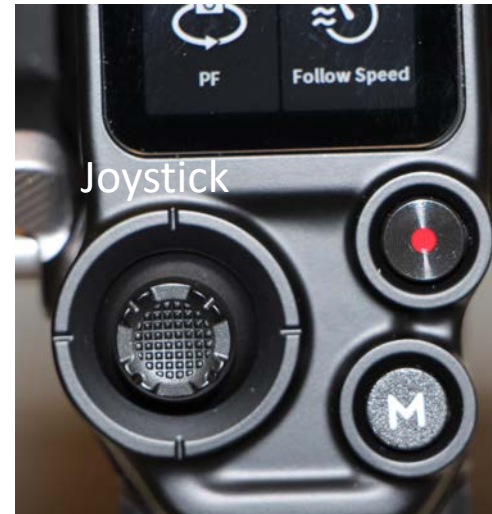

Other Basic Gimbal Controls

Trigger:

Double press the trigger on the front of the gimbal to re-centre the gimbal.

Press the trigger three times to make the camera turn to face the operator (unless selfie-mode is disabled).

Rec button: Press halfway for autofocus (make sure lens is set to AF). Press completely to record/standby.

M button: is for cycling between three possible user profiles. You can store different gimbal settings in each user profile.

For entering “sport mode” (P. 34 of this guide).



Record/
focus

Profiles

Controlling Exposure Remotely

In the (Sony a7Rr) camera menu, set the exposure in Movie Mode to Manual Exposure. (camera menu 2, page 1).

The f stop (aperture) dial on the prime lenses should be turned to “A” (auto).

The camera should be connected to the gimbal with the USB C cable.

If you can, set your exposure before you start shooting.

Change the dial functions on the gimbal to control aperture, shutter and ISO.

Swipe up on the touch screen to reach the Dial function menu.

If a change in exposure is required during the shot, choose ISO or aperture as the dial function to control one of those parameters. Never change the shutter speed during shooting unless you want a special effect. The shutter speed should remain at twice the frame rate.



Controlling Exposure and Roll Axis Simultaneously

But what if you need to control exposure **and** the roll axis manually while shooting?

In this case, go to a two person operation: the gimbal operator controls aperture or ISO manually with the gimbal dial while the second person controls the roll, tilt and pan parameters with the virtual joystick on the Ronin app, or vice versa! (See the section of this guide on the Ronin app.)

It requires cooperation!

OK, but what if you need to control exposure, manually focus and control the roll axis while shooting? Good luck!

Controlling Focus Remotely

The switch on the lens **should always be turned to AF** regardless of whether you want the camera to autofocus or whether you want to control the focus manually (remotely) with the gimbal dial.

Sony a7r III:

For autofocus: turn the lens switch to AF and set the focus menu setting to Continuous AF (AF-C) in the menu (Camera menu 1, page 5).

For manual focus: set the lens switch to AF and the focus menu setting to Manual in the camera. Set the dial function on the gimbal to focus. I recommend turning on focus peaking in the camera.



Important System Settings

Swipe left on the touch screen to get to the system settings.

These are the two most important settings:

Push mode: this enables manual control of the axes

Silent Mode: good idea to turn this on if you are recording audio

Other settings:

Disable Selfie: this stops the camera from turning to face the gimbal operator when the trigger is pressed three times

Steadycam mode: this can be turned on when the RS2 is attached to a steadycam or steadycam accessories

Create Settings

Swiping right from the main menu screen on the gimbal touch screen takes you to the **create** screen that has four options:

Timelapse, Track, Panorama and Time Tunnel.

Timelapse, Panorama and Time Tunnel are all variations of timelapse photography that allow you to combine camera movement with photos taken at a specific interval. Since all require the camera to take still images, you will have to use the USB C to Sony Multi cable with the Sony a7r III.

The **Track** function is better controlled through the Ronin app and will be discussed in that section of this guide.

Practical Advice

This guide concentrates on setting up the gimbal and learning the basic controls. Becoming familiar with the operation takes much more time and practise.

Here are some some more basic tips on using any gimbal by Peter Makholm:

<https://www.youtube.com/watch?v=gksaY-RpwG8>

Also, some general advice for safety:

if you are following or tracking a subject, have a friend spot you while you operate the gimbal. They can warn you of any obstacles or problems in the path of your feet.

The DJI Ronin App

DJI Ronin RS 2

Centre for Digital Arts

The DJI Ronin App: Downloading

Some features of the camera can also be controlled by the DJI app on your smartphone or tablet. The DJI app must be downloaded from the DJI website:

<https://www.dji.com/ca/downloads/djiapp/dji-ronin>

Unlock the motors and turn on the gimbal and connect to the device via Bluetooth (enable this feature on your phone). The device should be listed as: DJI RS 2-073F45.

You may have to type in the default password 12345678 to connect.

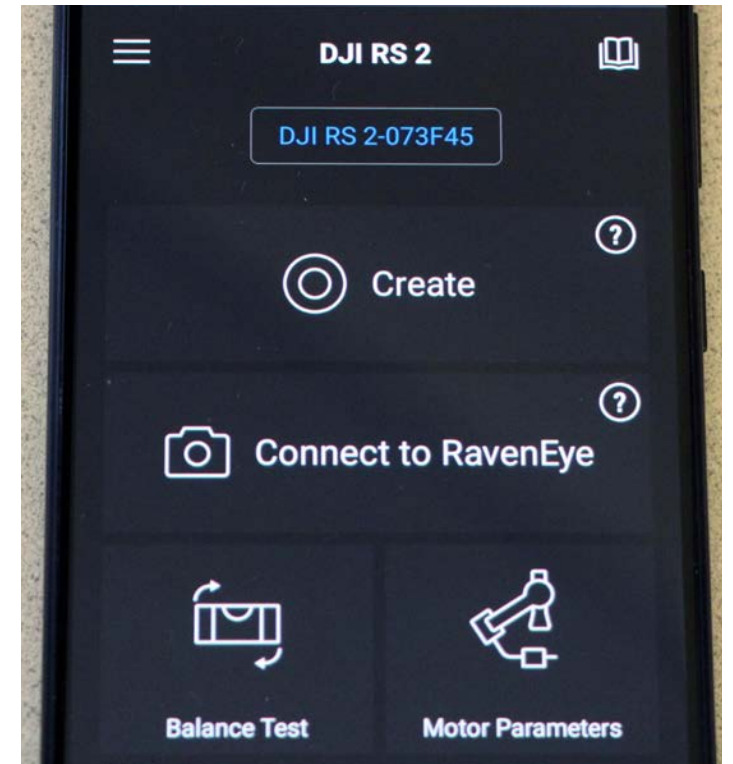

The DJI Ronin App: Create

Create menu/ Virtual Joystick:

The create menu in the app has three of the four options that are on the create menu in the gimbal (Timelapse, Track and Panorama).

One extra feature is the **virtual joystick** that allows you control all the axes of the gimbal, even the roll axis.



DJI Ronin App: Create

Create Menu/Track:

The Track function is best done with the app because it gives you a visual interface.

In Track, the camera follows through on a series of preplanned movements.

You can store up to ten sequential positions for the camera. When you press the record button, the camera moves from one position to another in the allotted time.

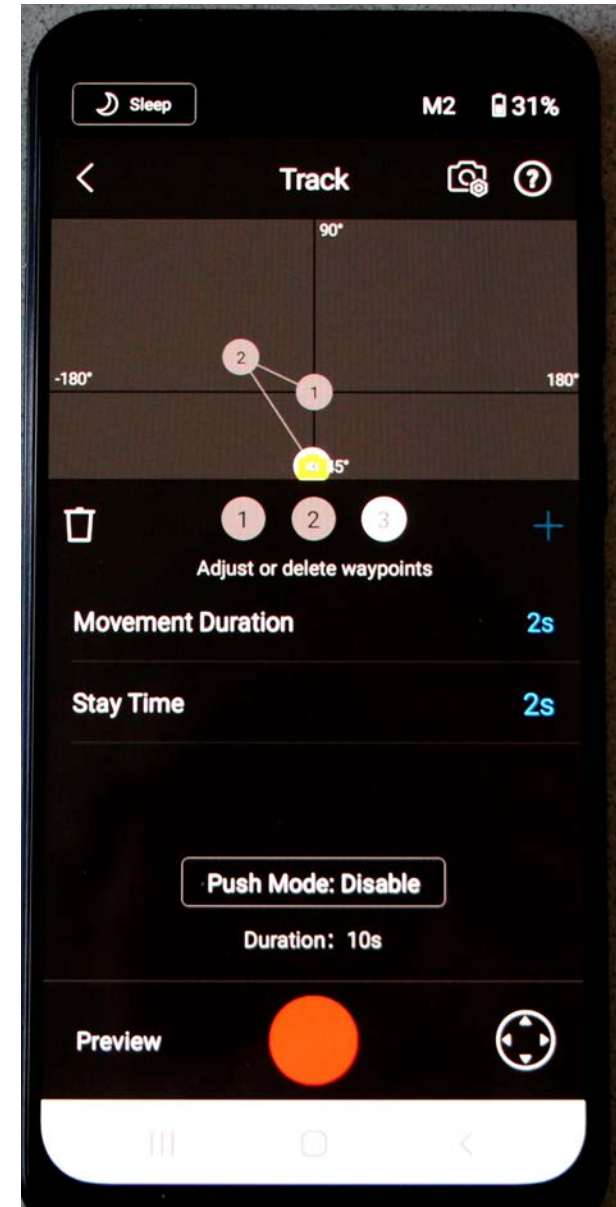

The DJI Ronin App: Create

Create Menu/ Force Mobile:

Another option in the create menu is **Force Mobile**.

When you enable force mobile, you can control the gimbal just by moving around your phone. The gimbal follows the phone's movements.

You should start with the phone in the upright position with the screen facing you.

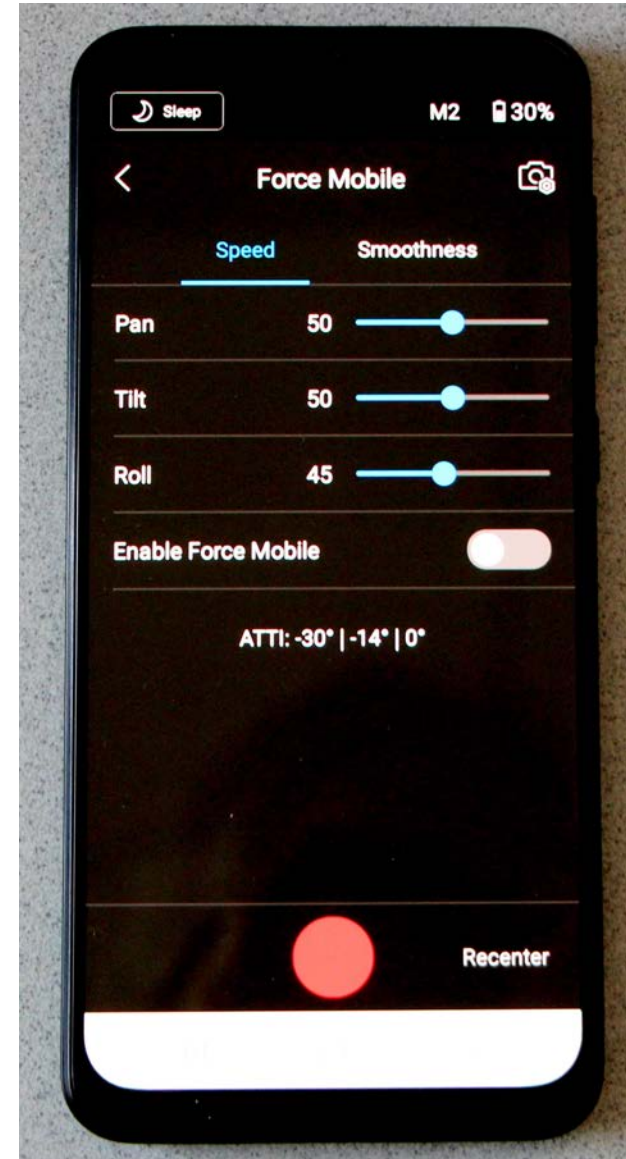

Accessories

DJI Ronin RS 2

Centre for Digital Arts

Twist Grip Dual Handles

Watch this video from DJI on how to setup the Twist Grip Handles:

<https://www.youtube.com/watch?v=zyyGK0-0rPU>

The kit does not include the Tethered Control Handle.

You must remove the rubber protector from the front of the gimbal to mount the arms.

Mount the arms on their correct side.

You can use one or two handles in conjunction with the hand grip.



Twist Grip Dual Handles

Mounting the left handle upwards by rotating the left arm to the “2” position is the best way to get low angle shots with the gimbal.

Use this method instead of the “underslung” operation mode where the camera is hanging from the handle.

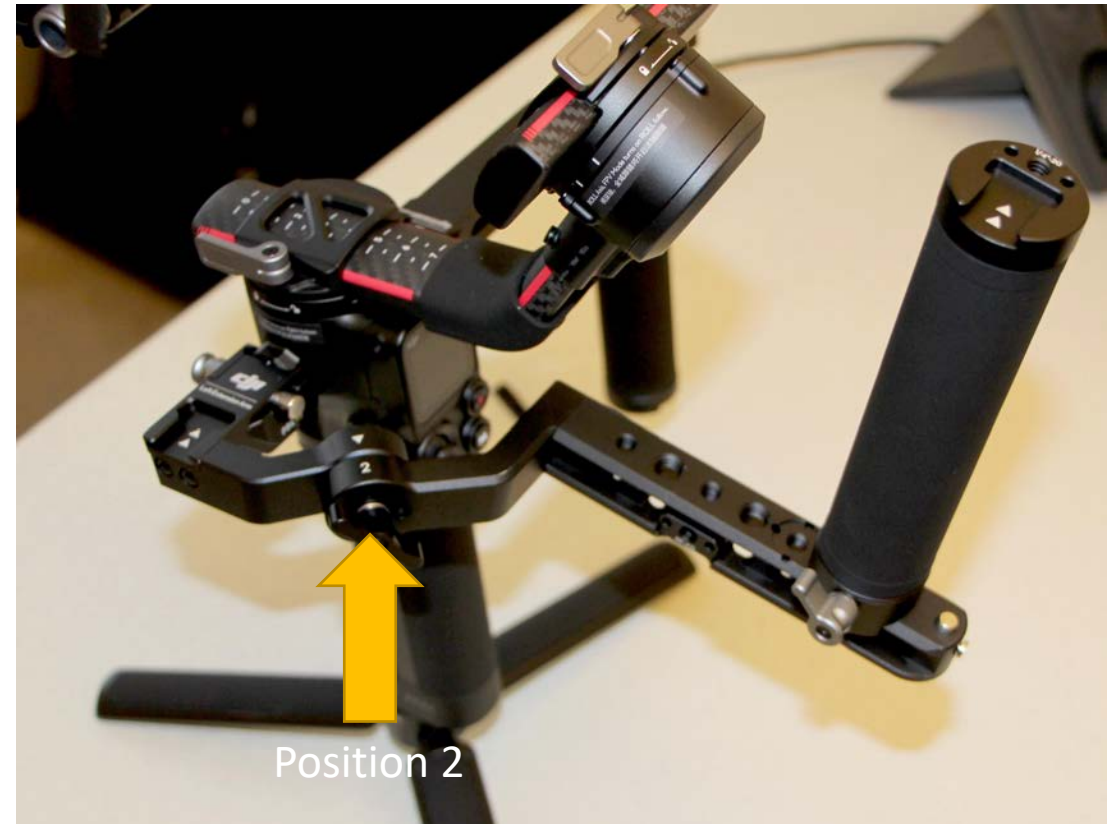

Accessories

There are accessories for the RS 2 manufactured by DJI and other companies, for example the Raven Eye transmission system by DJI.

Please feel free to suggest any for future upgrades to the kit. Please include the reasons for your suggestion.

Email:

philip.hawes@concordia.ca

or speak directly to the EV Depot staff.

Thank you for reading this guide

If you have any suggestions or comments

please email:

philip.hawes@concordia.ca